

RIGHT ANGLE PLUG SOLDER TYPE

R123.153.007

CABLE .085

Series : QMA

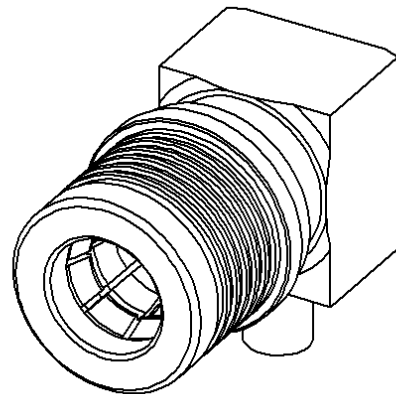
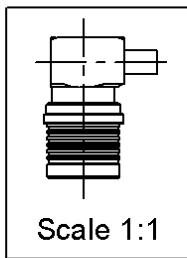
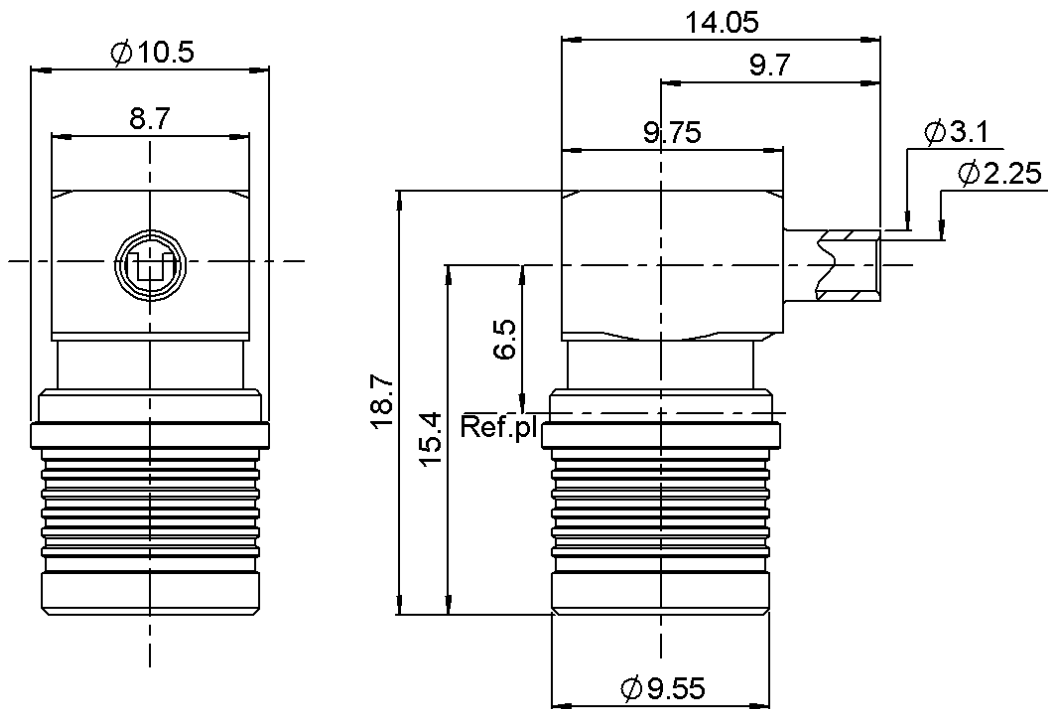

All dimensions are in mm.

COMPONENTS	MATERIALS	PLATING (µm)
BODY	BRASS	NPGR
CENTER CONTACT	BRASS	NPGR
OUTER CONTACT	BRASS	BBR 2
INSULATOR	PTFE	
GASKET	-	
OTHERS PARTS	BRASS	GOLD 0.2 OVER NICKEL 2
-	-	-
-	-	-

Issue : 0711 C

In the effort to improve our products, we reserve the right to make changes judged to be necessary.



RIGHT ANGLE PLUG SOLDER TYPE

R123.153.007

CABLE .085

Series : QMA

PACKAGING

Standard	Unit	Other
100	'W' option	Contact us

SPECIFICATION

1301-RPT 408 2009/01 Rev C

ELECTRICAL CHARACTERISTICS

Impedance	50	Ω
Frequency	0-6	GHz
VSWR	1.10 + 0,0020	x F(GHz) Maxi
Insertion loss	0.05	\sqrt{F} (GHz) dB Maxi
RF leakage	- (***80)	- F(GHz)) dB Maxi
Voltage rating	335	Veff Maxi
Dielectric withstanding voltage	1000	Veff mini
Insulation resistance	5000	M Ω mini

CABLE ASSEMBLY

Stripping	a	b	c	d	e	f
mm	3,17	0,00	0,00	0,00	0,00	0,00

Assembly instruction : **Solder 02**

Recommended cable(s)
 BELN YQ40246
 RG 405
 KS 1

Characteristics indicated on this data sheet are those that can be achieved with the highest performance cable. Intrinsic limitations of the cable may diminish the performance of the assembly

Cable retention

- pull off **130** N mini
 - torque **NA** N.cm

MECHANICAL CHARACTERISTICS

Center contact retention		
Axial force – Mating end	18	N mini
Axial force – Opposite end	27	N mini
Torque	NA	N.cm mini

TOOLING

Part Number	Description	Hexagon
.	.	.
R282.051.000	STRIPPING TOOL	
R282.063.000	POINTER GAUGE	
R282.740.000	SOLDERING MOUNTING	
R282.744.240	SOLDERING POSITIONER	

Recommended torque		
Mating	NA	N.cm
Panel nut	NA	N.cm
Clamp nut	NA	N.cm
A/F clamp nut	0,0000	mm

Mating life	100	Cycles mini
Weight	7,8590	g

OTHER CHARACTERISTICS

**Intermod.: -120dBc at 1.8GHz(2x20W)
 ***RF leakage(interface) 3<F<6GHz:>70dB

ENVIRONMENTAL

Operating temperature	-40/+80	$^{\circ}$ C
Hermetic seal	NA	Atm.cm3/s
Panel leakage	NA	

Issue : 0711 C

In the effort to improve our products, we reserve the right to make changes judged to be necessary.

